

WING303

Automated Arm Gate System



General Description

MAG WING303 is an electro-mechanical complete system for automatic arm gate system. It is composed with primary of an electronic panel unit that control actuator motor to open or close the gate in swing motion.

Applicable for residential home with single leaf weight not exceeding 250 kg.

Standard feature:

- Max gate weight per leaf is 250 kg
- Full DC operation to avoid any potential electric hazard
- Actuator capability for 90° opening within only 10 second
- No underground installation so no hole digging is required and minimum welding during installation
- Coded remote control allow 30 to 50 meter transmission
- Will continue to work during blackouts with backup battery with smart power saving feature
- Gates will automatically reverse if photo beam detects any object in its path
- With Dual Speed technology, gates closes fast but will slow down during closed position

Technical Specification:

Description	Parameter
Driving Method	Electro – mechanical screw driver piston type
Operating voltage	DC 18 V for first high speed DC 9 V for second low speed
Motor Output	15 watt per arm
Motor Amp.	2.1
Piston Displace	32 cm
Piston Speed	2.9 cm/sec
Back-up battery	12 volt. 7Ah rechargeable
Safety Clutch	Electric current sensing using Hi-Amp Auto stop if any obstacle blocking
Electric Controller	Micro-processor based
Temperature	0 to 80°C
Gear Box	Three stages planetary reducer
Manual Operation	Special released key during power failure
Max. Weight of gate	250 kg per wing with force adjustable

Ordering information:

Ordering code: WG303P2
System package consist of the following:

1 pair	MAG WING WG303 arm motor
1 set	MAG MW40 control panel w/ transformer
1 nos	Weatherproof PVC box
1 nos	12V, 7.2 aH backup battery
1 set	Remote control (1 receiver, 3 transmitter)

Accessories:

Push button plate, additional remote control transmitter.



Dimension of the actuator arm:

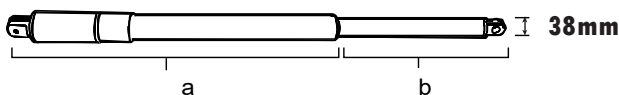

Types of actuator arm motor

	a	b
WG303T	66cm	34.5cm
WG303M	66cm	25.5cm

Typical Installation Diagram:

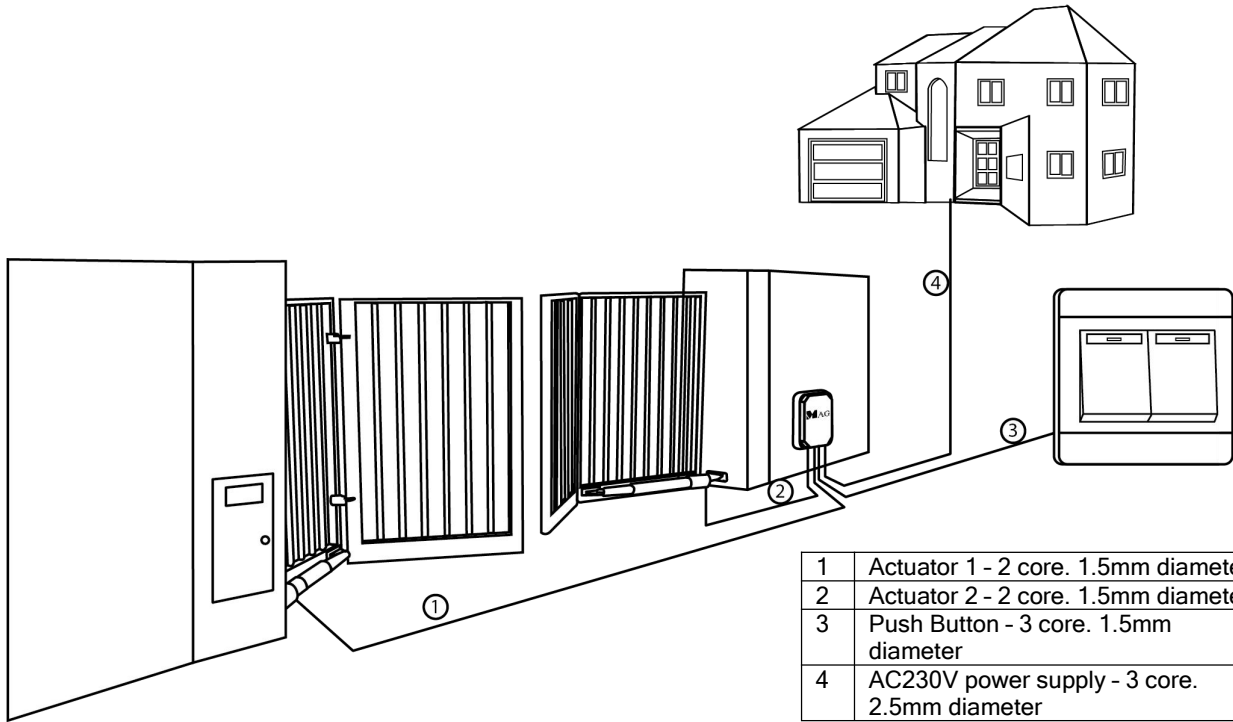

1	Actuator 1 - 2 core. 1.5mm diameter
2	Actuator 2 - 2 core. 1.5mm diameter
3	Push Button - 3 core. 1.5mm diameter
4	AC230V power supply - 3 core. 2.5mm diameter

Typical Installation:

Dimension structure for folding gate

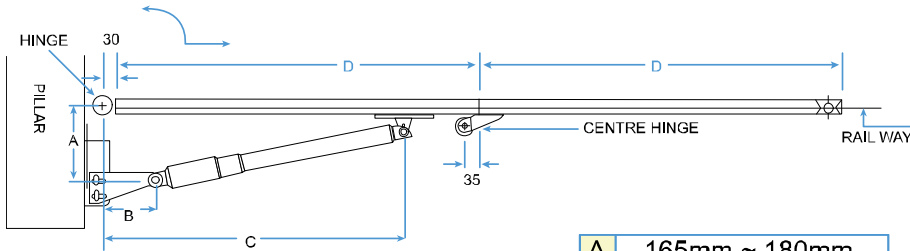

A	165mm ~ 180mm
B	128mm ~ 140mm
C	816mm ~ 837mm
D	Min.1000mm

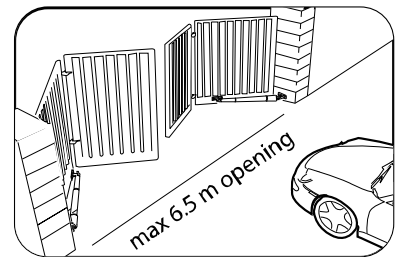

Dimension structure for swing gate

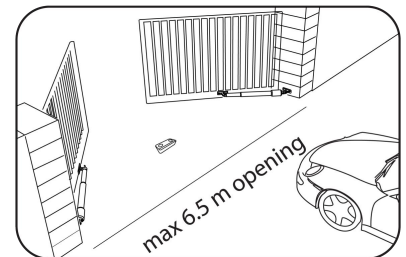
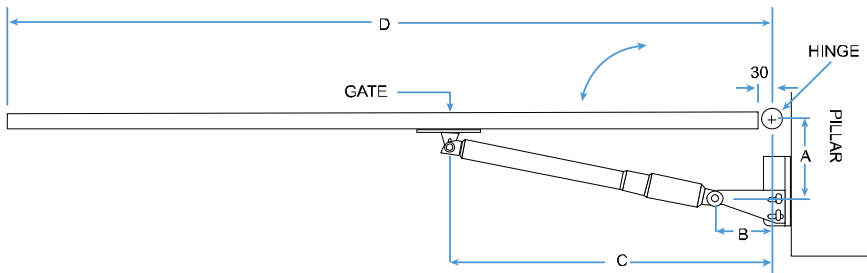

Manual Release Key

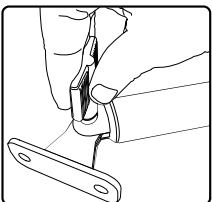

Technical Specification:

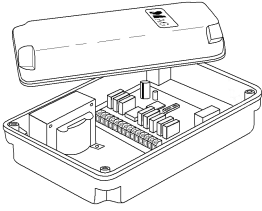

Control panel
 Consists of an advanced microprocessor based PCB, and transformer housed in weather resistant casing. Controls operation of the whole swing auto gate system.

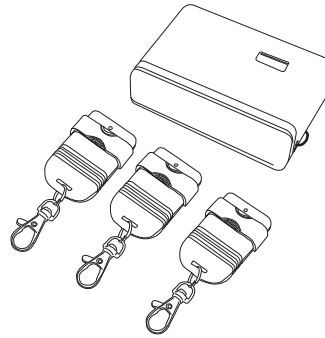

Remote control & transmitter
 Consist of a receiver and transmitters. Allows gate operation to be controlled remotely within the specified range.

Functions:

- Adjustable Dual speed gate control
- Gate leaf opening and closing with cushioning
- Automatic pillar light control
- Single or two gate leaf open; selectable from remote control transmitter or in house push button
- Adjustable opening/closing angle. Gate can be stopped immediately and resume motion at any angle.
- Adjustable safety collision force to cut of motor power.
- Built in secondary transformer to protect control panel from possible electric surge to provide consistent motor performance.
- Built in charger to support backup battery

Range	Effective 30m.
Transmitter dimension	6 x 3.5 x 1.3 cm
Receiver dimension	9.5 x 5.4 x 2.6 cm

Modulated RF transmission. Transmission coding (6561 combinations) is set by 8x3 DIP switches in the receiver and transmitter - easily accessible and changed by owner. Coding on both sides must be the same for it to work.

Receiver is installed inside the ABS casing together with control panel. Transmitter uses a single 12V small size alkaline battery - normal usage should last 6 months. First button for full open and second button for half open.

Housing is made from weather proof ABS plastic.
 Housing dimension: 25.5 x 31 x 12 cm

Packaging information

Single complete system of WG303 (with any possible optional items) can be packed into the following two boxes for shipment.

Approximate total weight = 11 kg

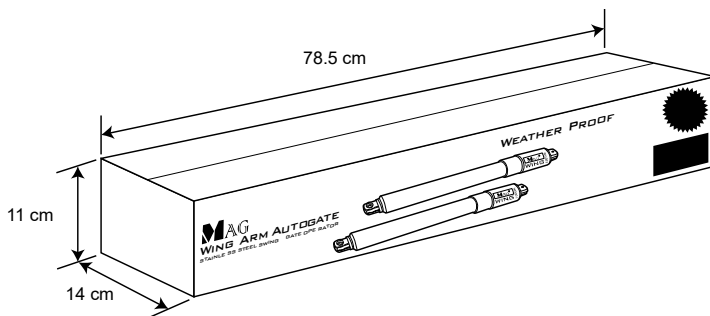

Two arms, 1 stopper, release key, brackets & screws

No backup battery = 5 kg
 Including backup battery = 7 kg

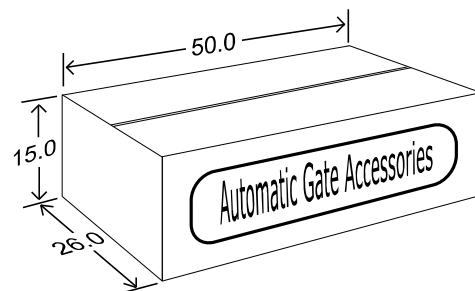

Control panel, solenoid lock, L-bar, angle bar, keys, remote control receiver & transmitter and any other optional accessories.

© COPYRIGHT 11 Aug 202. This documentation served as a reference only. It is subject to change without further notice. All the diagrams and information in this documentation may not be duplicated or modified in any form without the written approval from the management.