

EL250 Electric drop bolt lock (fail safe)

WWW.MAG.COM.MY



Description

EL250 is an electric operated drop bolt lock. Operation is based on electromagnet and the design is continuously improved, refined and tested until failure to yield product with outstanding performance. Optimized manufacturing flow allow EL250 to be a very cost competitive solution in the market.

Suitable for office buildings as well as residential premises.

Features

1. **Fail safe operation.** Power up to lock the door but when there is emergency power cut off, EL250 will release the door for everyone to safely evacuate.
2. **Built in adjustable re-lock timer.** Delay timer for door closing (DIP switch adjustable 0/3/6/9 sec) starts after the door is aligned with drop bolt. Hence EL250 can be use with a simple push button access control system.
3. **Door surveillance output.** Magnetic contact output (gusset plate on the door) to indicate if the door has been opened or close. With this feature EL250 can be interfaced to any access control system, alarm system or just a simple buzzer for higher security level of monitoring purposes.
4. **Durable and money saver.** EL250 using good quality magnets raw material processed and together with special unique techniques to ensure no residual magnetism over period of time. This drastically reduce failure rate and any maintenance required.
5. **Stylish and Elegant.** Premium finishing and the cover plate give better cosmetic appearance after installation.
6. **Low power consumption.** With only 100mA for normal operating current to lock the door for 24hour, help us save more money on electric bill and more green to environment.

Technical Parameter

Power	DC12V
Operating Current	100mA
Starting current	1000mA
Lock Force	Up to 800 kg
Magnetic contact Rating	0.5Amp, 28VDC max
Magnetic contact detection distance	8mm
Drop Bolt Material	Solid stainless steel Ø14mm diameter
Operating Humidity	0~90% (non condensing)
Operating Temperature	0~55°C (14~131°C)
Weight	0.7kg
Dimensions (L x W x H)	(L)205 x (W)35 x (H)40mm

Wiring

Magnetic sensor output:
 Blue - COM
 White - N.O.
 - Trigger when gusset plate at door is detected

Power supply:
 Red is 12V and Black is GND

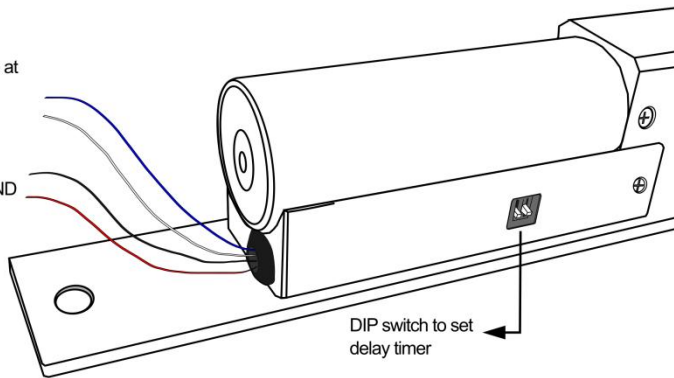

Delay timer setting configuration:

Time	DIP SWITCH
0sec	ON
3sec	ON
6sec	ON
9sec	ON

** Need to be re-configured for every new installation to minimize door sway.

Dimension Specification

* Both diagram is not scaled relative to each others. Diagram are enlarged individually to show the dimension more clearly. Unit in mm.

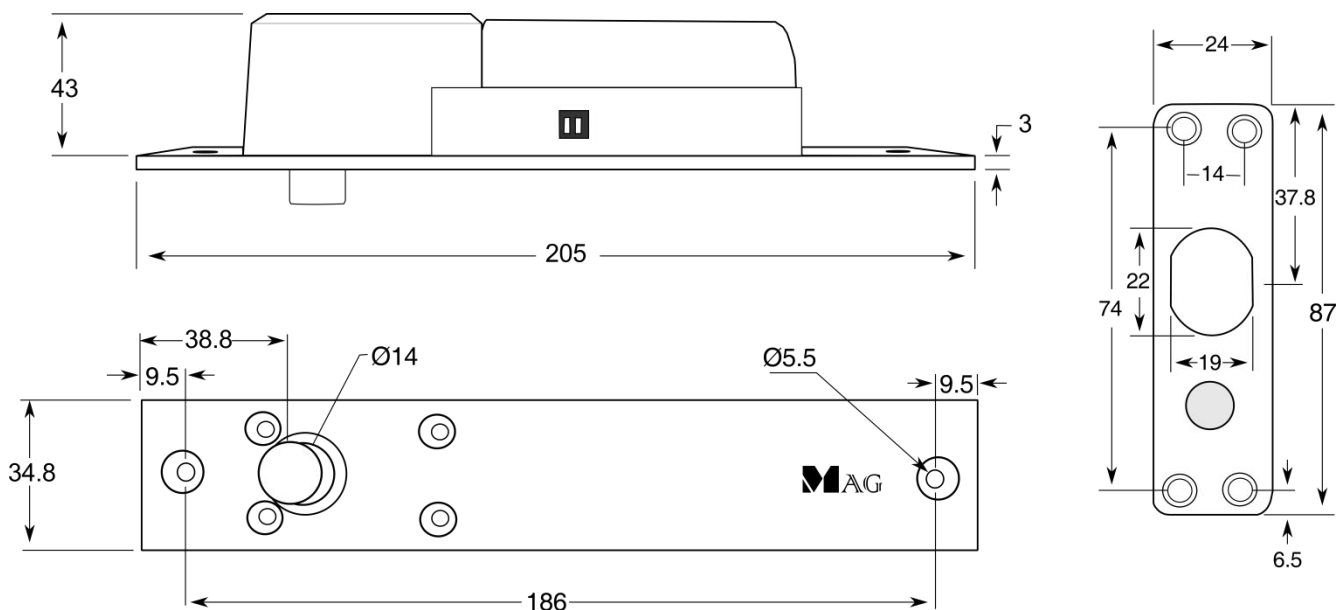

Installation diagram for framed door

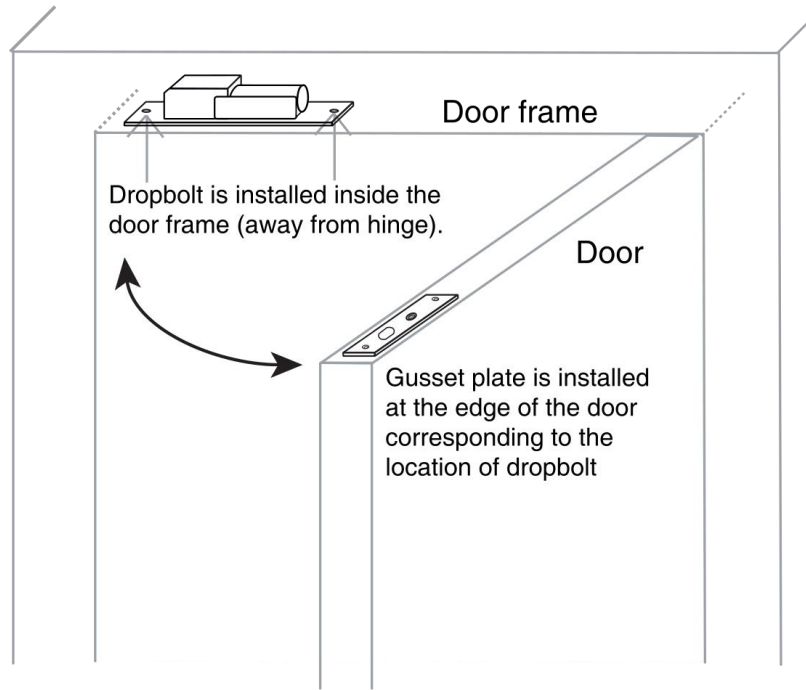

fig 1: Dropbolt and gusset plate mounting location on framed door.

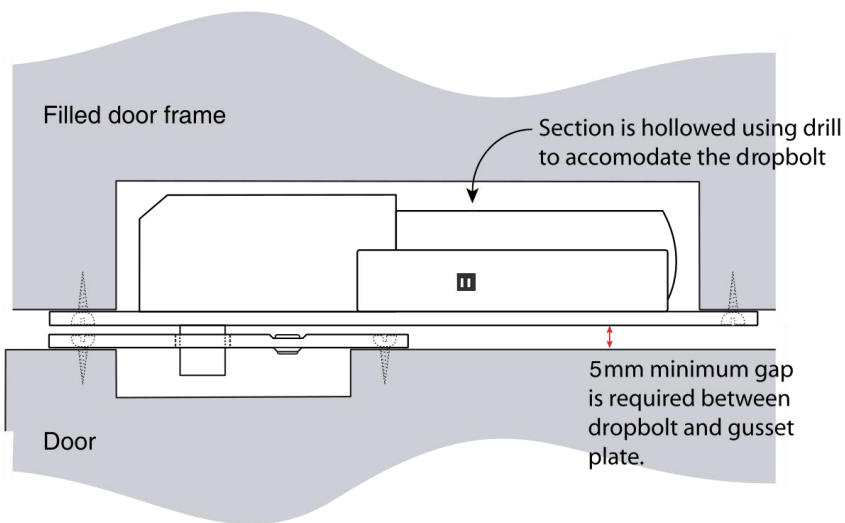

fig 2: Side cross section diagram when door is closed for filled door frame

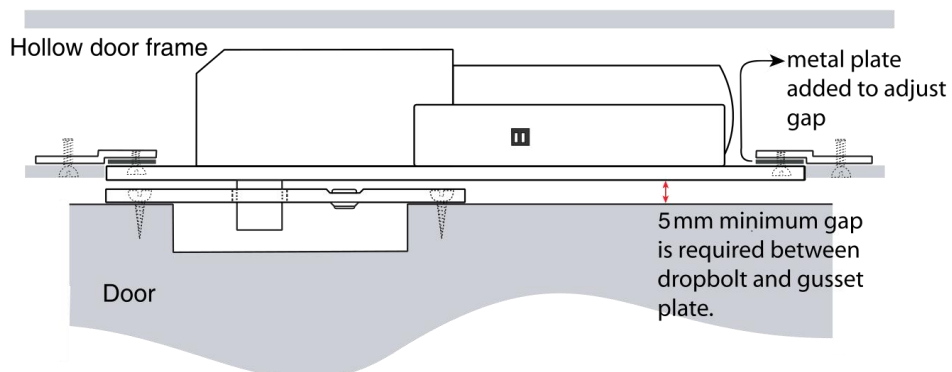

fig 3: Side cross section diagram when door is closed for hollow door frame

Installation diagram for frameless door

EL250BR-A mounting bracket is suitable for both upper frameless glass panel or frameless glass door application.

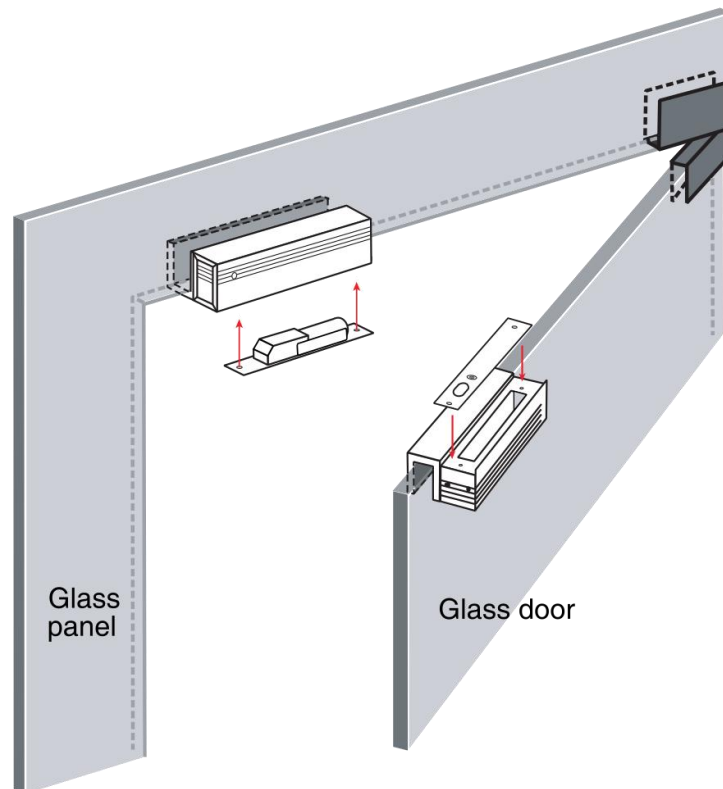

fig 4: EL250BR - A bracket mounting location on frameless glass panel and glass door

Installing drop bolt

1. Apply silicone sealant into the U channel of EL250BR-A bracket.
2. After confirm the position of EL250 drop bolt lock, mount the bracket to the glass panel accordingly.
3. Hold tight the bracket on it's position until the silicone sealant is fully dry and bond with the glass panel.
4. After the bracket is securely mounted onto the glass panel, mount the drop bolt lock to EL250BR-A bracket.

Installing the gusset plate

1. Apply silicone sealant into the U channel of EL250BR-A bracket.
2. After confirm the position of EL250 gusset plate, mount the bracket to the glass panel accordingly.
3. Hold tight the bracket on it's position until the silicone sealant is fully dry and bond with the glass panel.
4. After the bracket is securely mounted onto the glass panel, mount the gusset plate to

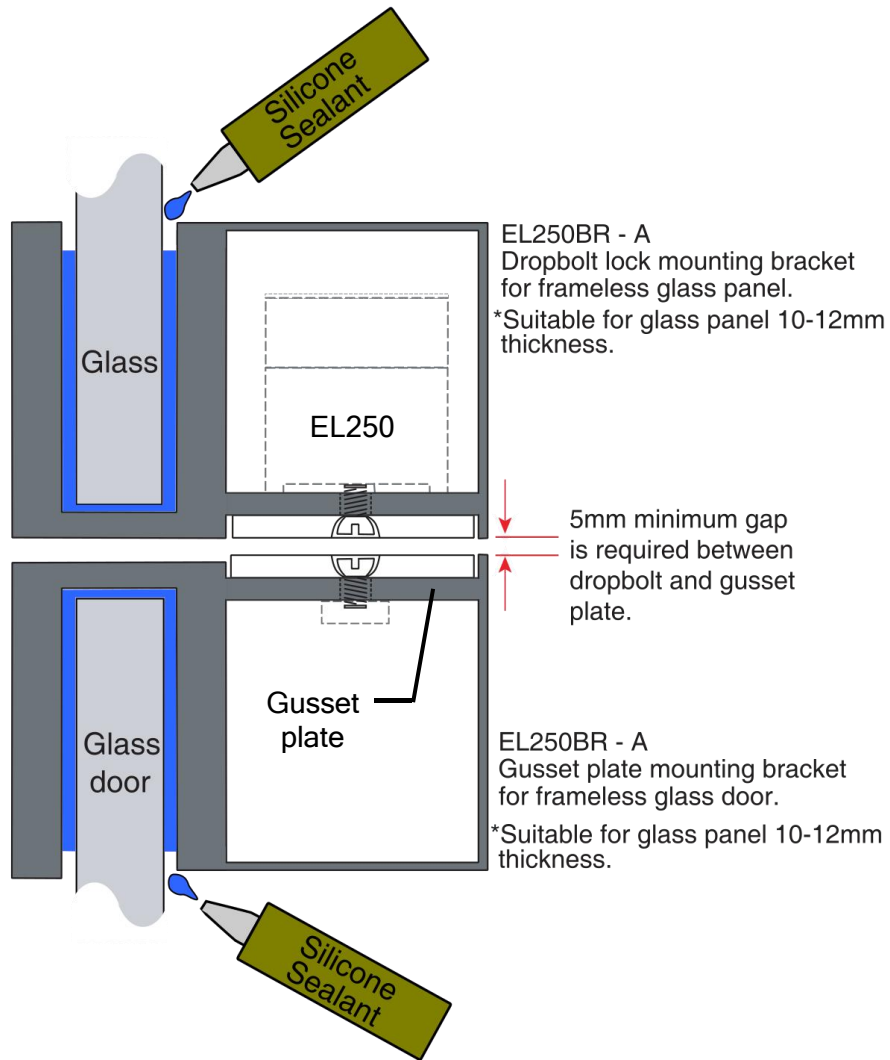
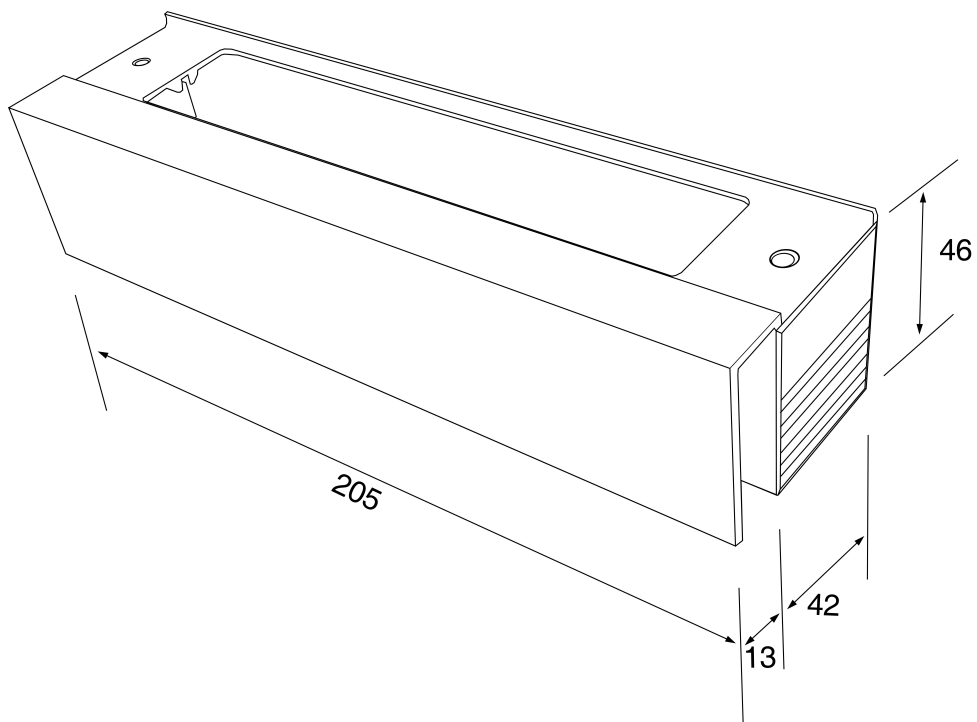

fig 5: Front cross section diagram when door is closed.



Installation diagram for surface mount application

EL250BR-B mounting bracket is suitable for surface mount application. Etc concrete, metal or wooden surface that can directly screw the bracket to it.

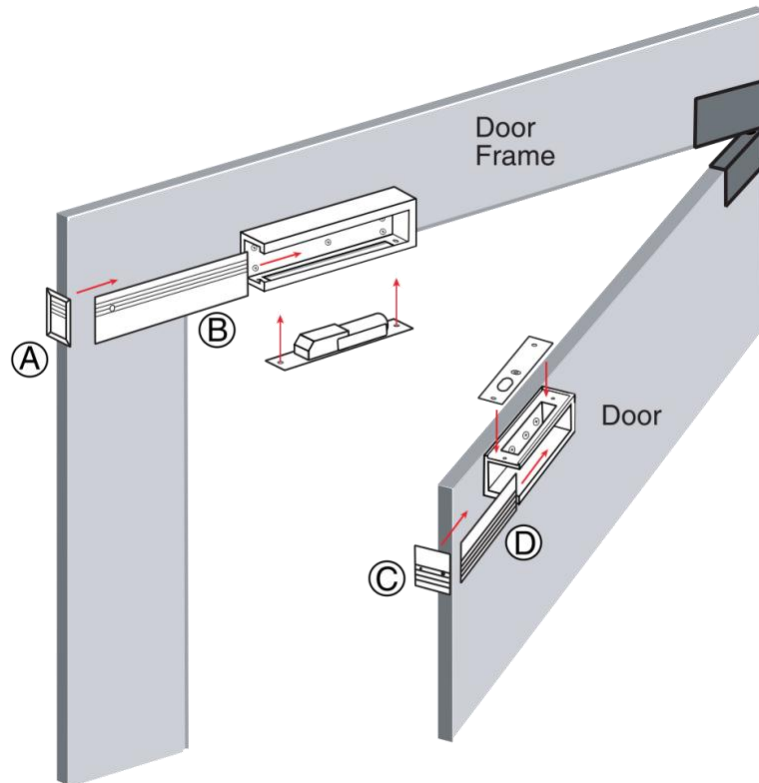

fig 6: EL250BR - B bracket mounting location on door frame and door.

Installing drop bolt

1. Dismantle EL250BR-B long bracket into A and B.
2. Mount EL250BR-B long bracket to door accordingly with screw.
3. Mount EL250 drop bolt lock to the long bracket.
4. Slot back B to EL250BR-B long bracket.
5. Close back A to EL250BR-B long bracket with screw.

Installing the gusset plate

1. Dismantle EL250BR-B short bracket into C and D.
2. Mount EL250BR-B short bracket to door accordingly with screw.
3. Mount EL250 gusset plate to the short bracket.
4. Slot back D to EL250BR-B bracket.
5. Close back C to EL250BR-B short bracket with screw.

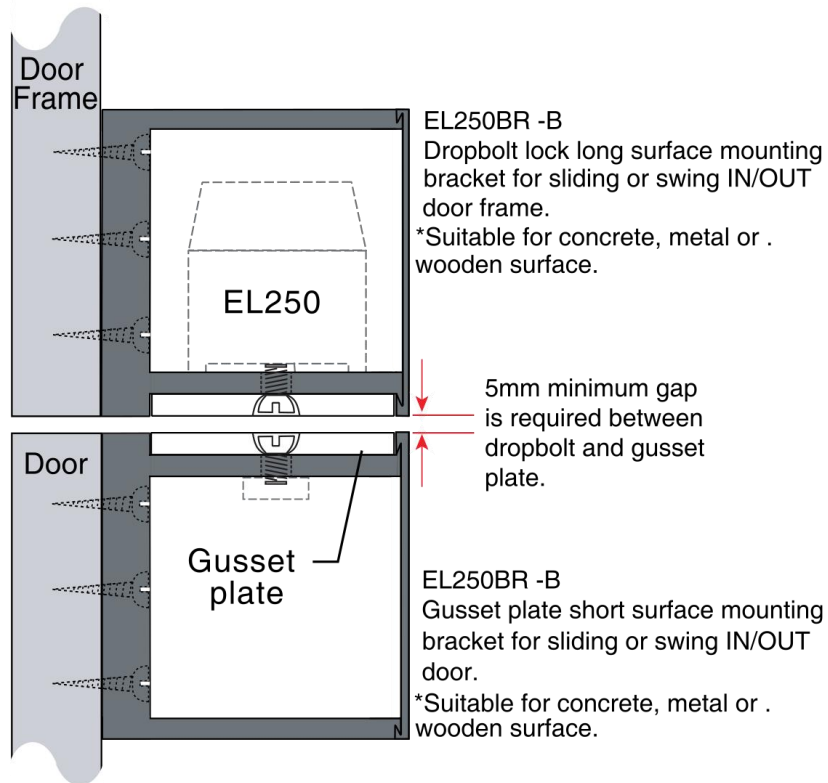
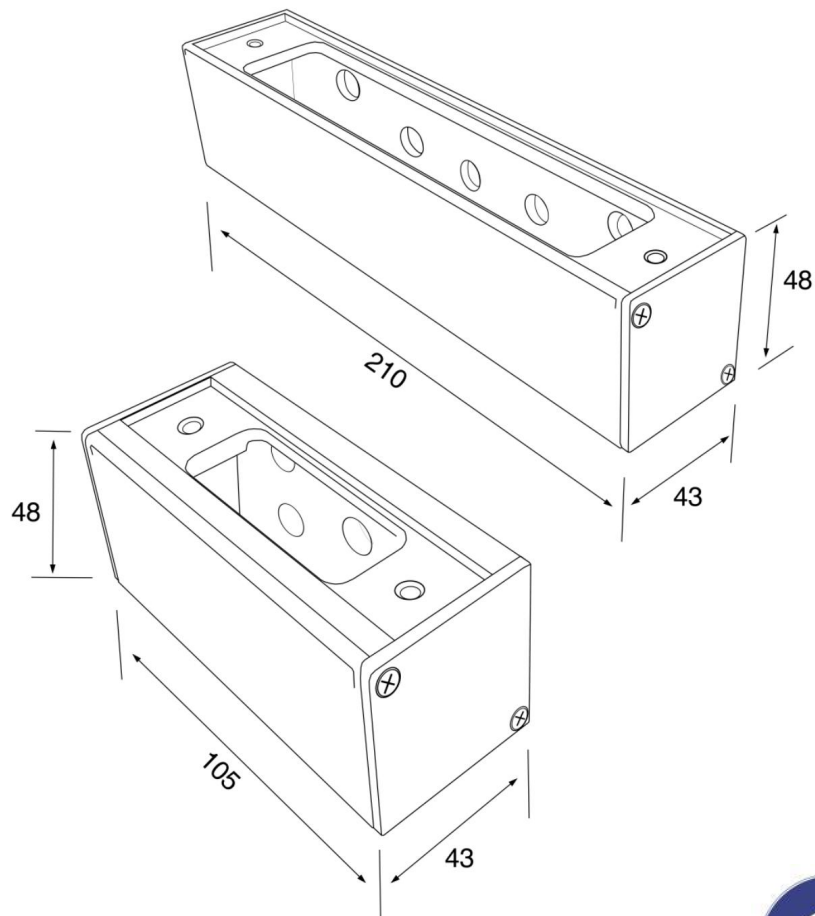

fig 7: Front cross section diagram when door is closed.



***Product performances is based on testing in a controlled environment. Your result may vary due to several external and environment factors.**



© COPYRIGHT 2022. This documentation served as a reference only. It is subject to change without further notice. All the diagrams and information in this documentation may not be duplicated or modified in any form without the written approval from the management.

© 2022 SP V1 EL250