

Contents

① Product

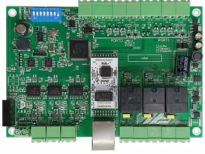

② Panel Mounting Base (AR-716-E16-X)



Option

AR-701B-X
Fit 35mm DIN Rail or Mount directly

③ Metal Box (AR-716-E16-M)



Option

Specification

CPU	32bit / ARM32 72MHz / Flash 512KB	Temperature	-20°C ~ +70°C	Aux. WG Port	WG 26 / WG 34
Memory	2048KB (2MB)	Digital Input	2 Door Open Button/ 2 Door Sensor/ 1 Fire-alarm	Anti-pass-back	16 Doors
Power Supply	9 ~ 24VDC	Relay Output	2 Door Relay / 1 Alarm Relay	Lift Control	Yes
Power Consumption	< 3W	Door Relay Time	Toggle, 0.1~600 Sec.	Door Group	255
Interface /	RS-485 : 9600 bps (N, 8, 1)	Alarm Relay Time	Toggle, 0.1~600 Sec.	Time Zone	63 (stand-alone /networking)
Baud Rate	Ethernet : 10/100M Base T	User Capacity	16,000 (Default value) / 32,000 / 65,000	Real-time Clock	YES
External Readers	2 RS-485 + 2 WG	Event log	32,000	DIP_SW	8 (Node ID: 1~254)

Connector Table

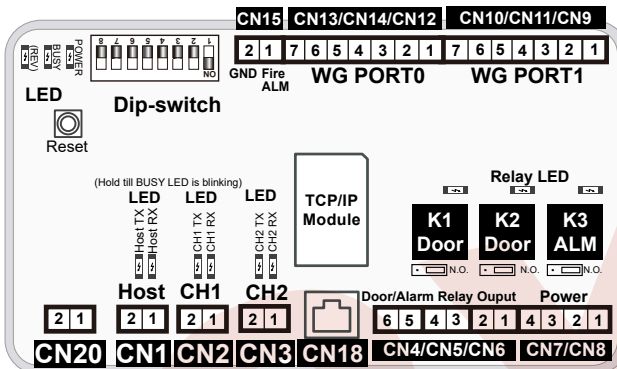

Connector CN1 Host RS-485

Code	Pin	Description
LA+	1	Host RS-485(A+)
LB-	2	Host RS-485(B-)

Connector: CN2 CH1 Slave RS-485

Code	Pin	Description
LA+	1	RS-485(A+)
LB-	2	RS-485(B-)

Connector CN3 CH2 Slave RS-485

Code	Pin	Description
LA+	1	RS-485(A+)
LB-	2	RS-485(B-)

Connector CN4/CN5/CN6 WG Door / Alarm Relay

Code	Pin	Description
Alarm Relay	1	K3-N.O./N.C.
Output	2	COM
Door 1 Relay	3	K2-N.O./N.C.
Output (WG1)	4	COM
Door 0 Relay	5	K1-N.O./N.C.
Output (WG0)	6	COM

Connector CN15 Fire-alarm Input

Code	Pin	Description
Fire-ALM	1	Fire-alarm Input
GND	2	DC Power 0V Output

Connector CN20 Isolated IO Power Output

Code	Pin	Description
V-	1	0V
V+	2	5V (Max. 50mA)

Connector CN7/CN8 Power Supply

Code	Pin	Description
GND	1	0V Input
VIN (716-E16)	2	9~24VDC Input
GND	3	0V Output
VOUT(Slave units)	4	9~24VDC Output

Connector CN9/CN10/CN11 WG Port 1

Code	Pin	Description
WG0	1	Wiegand DAT: 0 Input
WG1	2	Wiegand DAT: 1 Input
BZ	3	Beeper Output
LEDG	4	LED Green Output
LEDR	5	LED Red Output
SEN (N.C.)	6	Door Status Input
EGR: PB (N.O.)	7	Exit Button Input

Connector CN12/CN13/CN14 WG Port 0

Code	Pin	Description
WG0	1	Wiegand DAT:0 Input
WG1	2	Wiegand DAT:1 Input
BZ	3	Beeper Output
LEDG	4	LED Green Output
LEDR	5	LED Red Output
SEN (N.C.)	6	Door Status Input
EGR: PB (N.O.)	7	Exit Button Input

Connector CN18 Host TCP/IP

Code	Pin	Description
TCP/IP Socket	1	CAT5

Installation

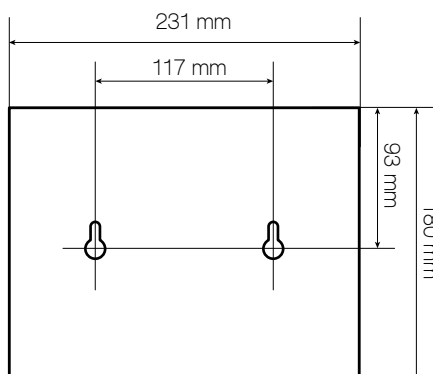

← Metal Box

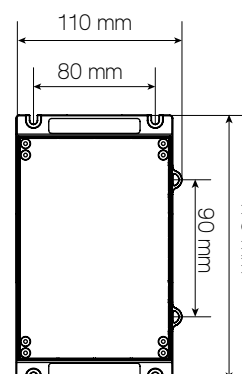

← Plastic Mounting Base

Hardware Architecture

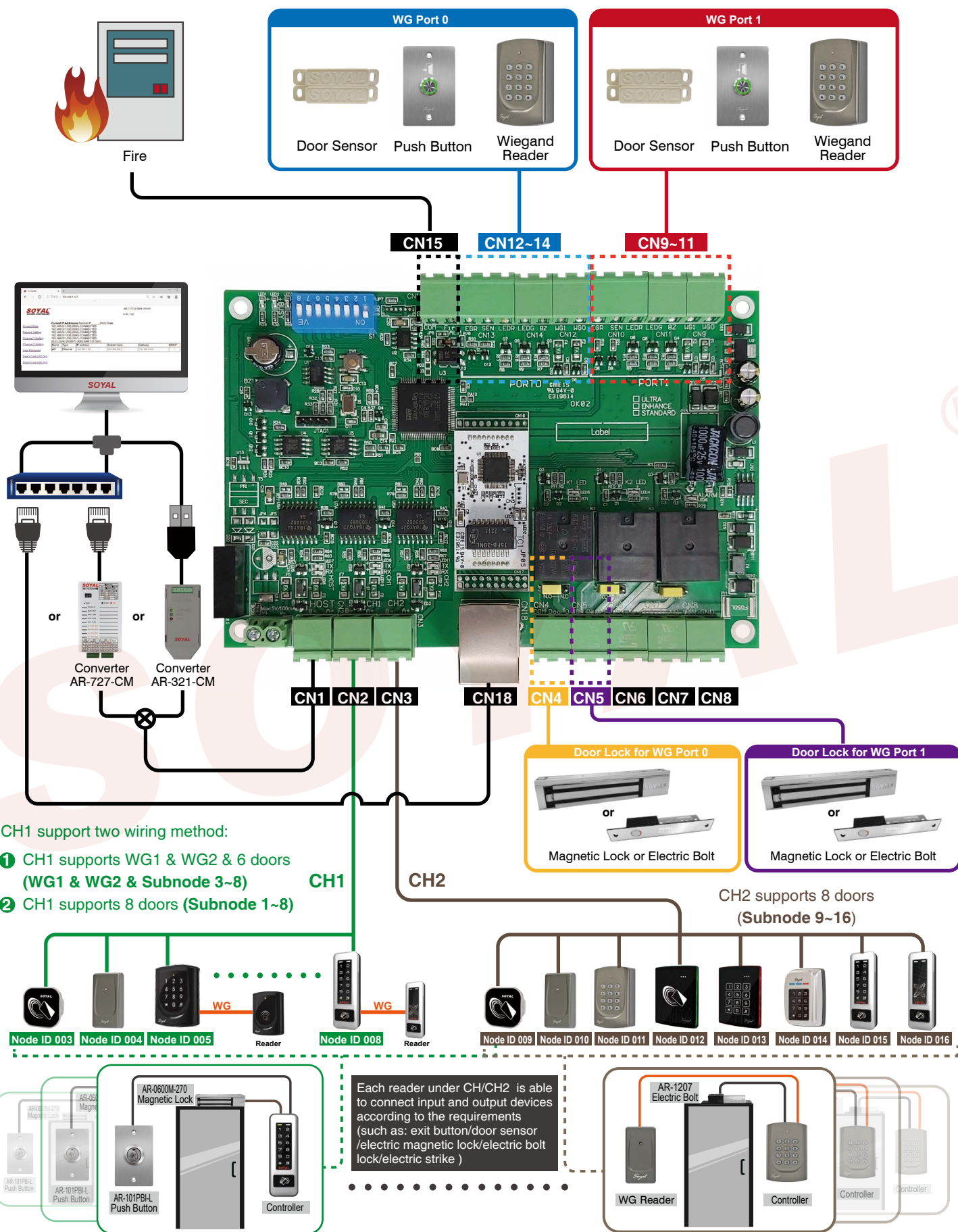

Wiring Diagram

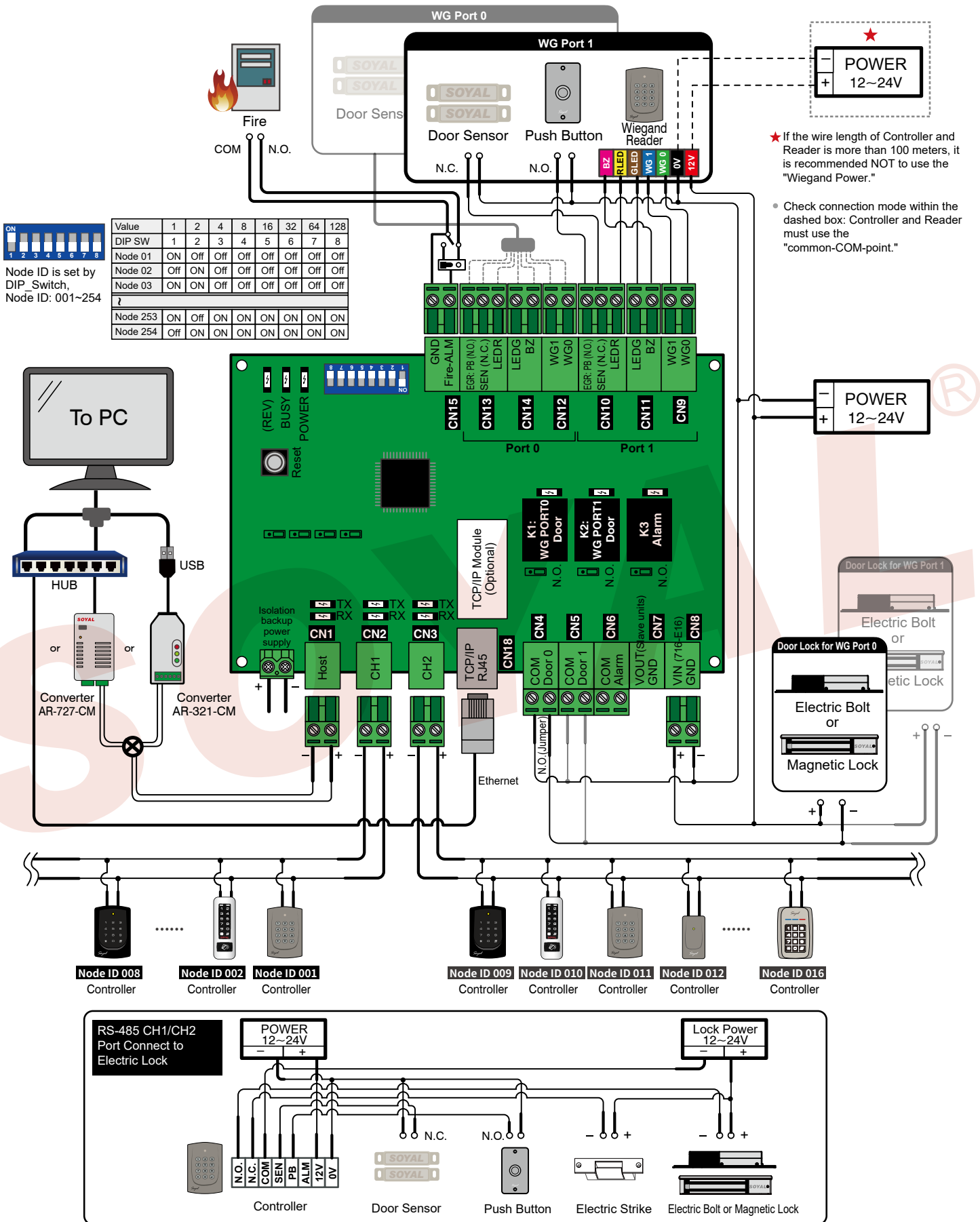

IP Setting

- Open your Web Browser and input factory default IP address: <http://192.168.1.127>

If the IP address of AR-716-E16 has been changed, we must enter the new IP address.

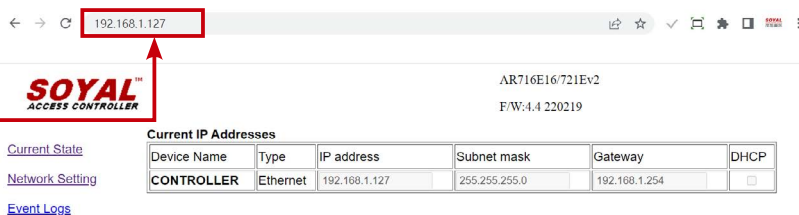

- Page menu

- [Current Status](#) ← Monitor the on-line computer
- [Network Setting](#) ← IP Setting
- [User Password](#) ← Change the Log-in information

- Current State

Online Status is able to be monitored showing which computer is linking on Ethernet Module

Current IP address of the AR-716-E16

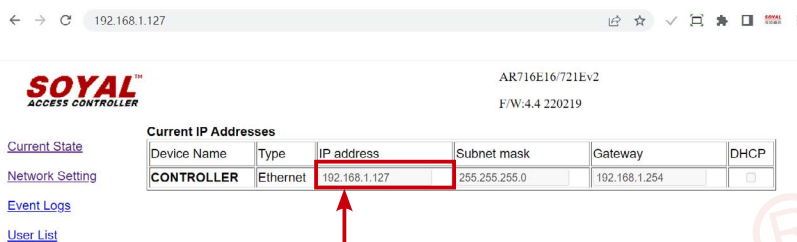

- Log-in User Password

When you choose the "Networking Setting" or "User Password," Log-in window will pop out and please input user name and password.

※ At the Factory Default Status -

User name: SuperAdm

Password: 721568

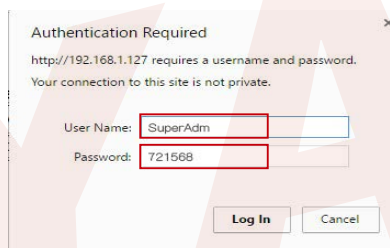

- Networking Setting

You will see initial IP Address 192.168.1.127 and make sure MAC Address is identical to the sticker on Ethernet Module device. Please alter the IP address as you want, and then click "Update" button. After updating the IP, please re-connect the Web Browser with the new IP address.

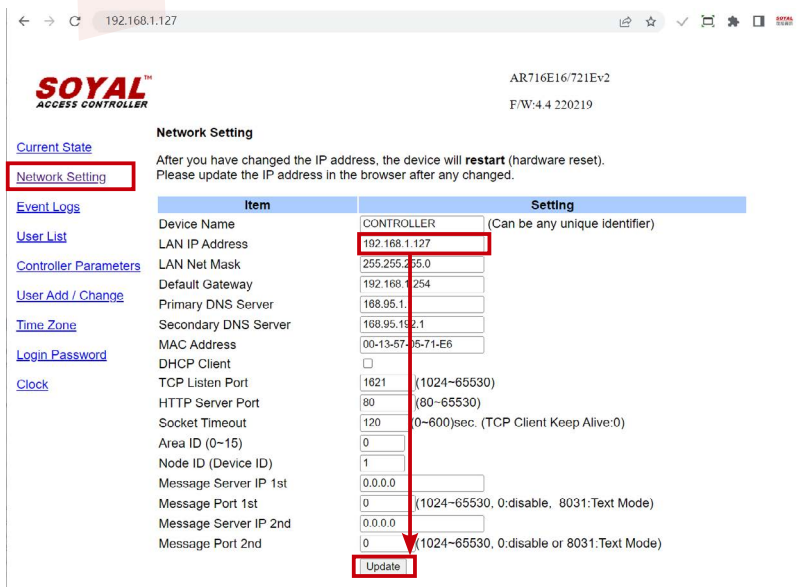

- User Password

Change the log-in password to lock the IP setting of Ethernet Module.

The password can be made up of 10 characters at most, and it can be either A~Z or 0~9.

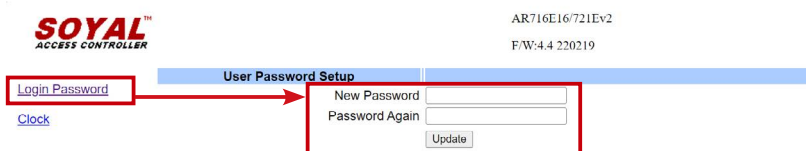



Initial Setup:

Software: Connection

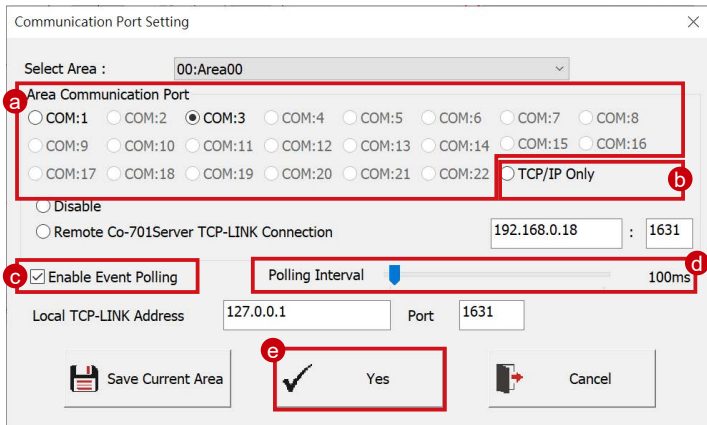
1. Open the "701 Server" Software → There are two ways to open the Communication Port setting window:  and → Communication Port Setting



- a. According to the computer Detection results to select the port (Use the RS-485)
- b. Select [TCP/IP Only] (Use the Ethernet)
- c. Select the option: Polling Message From Controller
- d. Polling Interval: 200ms - meaning the PC polls the controller every 200ms once it accesses the message from the controller
- e. Click YES

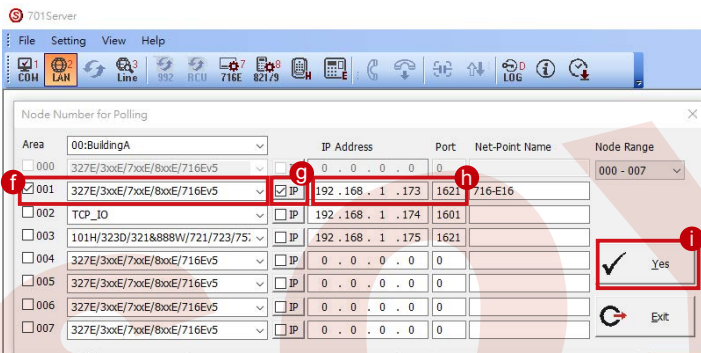

2. After COM Port setting, there are two ways to open the Node Number for Polling window:  and  → Node Number for Polling

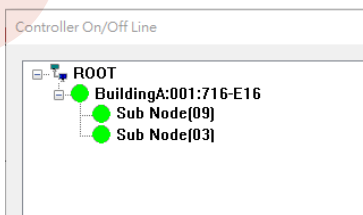

- f. Select node ID (for example:001) and access controller "327E/3xxE/7xxE/8xxE/716Ev5"
- g. If use the Ethernet mode, please check the "IP"; if use the RS-485 mode, there's no need to check
- h. If use the Ethernet mode, input IP in "IP Address" column (Default value: 192.168.1.127)
- i. Input 1621 in "Port" column(Default value: 1621; the Port number is predetermined by SOYAL for connection to the network)
- j. Select LAN BASE
- k. Click YES

3. Open Controller On/Off Line window to check the device connection status: 



-  Well: controller successfully connected to PC.
-  Not connected well: the following checks are required.

Software: Parameters Setting: Door Number and Users Edit

1. After the 701Server Software connection, go click 82xEV5 Parameters Setting  to set up 716-E16's door number

- a. Roll and select the Target Node ID of 716-E16 (The same as the dip-switch)
- b. Click "Read" to read back the parameter of 716-E16
- c. Click "716-E16" button to set up Door Number
- d. Input the new Door Number of Slave Reader, which door number must be unique and non-repetitive

Controller Parameters

Node ID	Door #	Relay Port	Node ID	Door #	Relay Port
CH1 (01/WG0)	<input type="checkbox"/>	None	CH2 (09)	<input checked="" type="checkbox"/>	9
CH1 (02/WG1)	<input type="checkbox"/>	2	CH2 (10)	<input checked="" type="checkbox"/>	10
CH1 (03)	<input checked="" type="checkbox"/>	None	CH2 (11)	<input type="checkbox"/>	11
CH1 (04)	<input type="checkbox"/>	4	CH2 (12)	<input type="checkbox"/>	12
CH1 (05)	<input checked="" type="checkbox"/>	5	CH2 (13)	<input type="checkbox"/>	13
CH1 (06)	<input type="checkbox"/>	6	CH2 (14)	<input checked="" type="checkbox"/>	14
CH1 (07)	<input type="checkbox"/>	7	CH2 (15)	<input type="checkbox"/>	15
CH1 (08)	<input type="checkbox"/>	8	CH2 (16)	<input type="checkbox"/>	16

Remarks:

WG0:

- Connect to WG reader: tick off the option, do not required to set door number, 701Client will indicate door number 17 automatically, triggering K1 relay.

WG1:

- Connect to WG reader: tick on the option and set the door number

CH1: RS-485 Reader Node ID must be set up from 01 to 08 or 03 to 08

CH2: RS-485 Reader Node ID must be set up as 09 to 16

Factory Reset

Reset Button:

Step1: After powering on the device, please firstly connect **Fire** contact on **CN15** to **GND** Ground.

Step2: Press [RESET] button on the main board for more than 5 seconds till the BUSY LED is blinking ,release [RESET] button.

Step3: After reset, the device will automatically restart and the IP address will be changed back to default value : 192.168.1.127

Step4: Disconnect **Fire** contact on **CN15** from **GND** Ground.

Remarks: LED Description

• POWER LED

When the controller is connected to the power, [POWER] will turn on green LED; if there is no light, it means the power supply has some problems.

• BUSY LED

When the red LED is lit, the memory is being cleared and restored to the factory default action.

※ If you do not perform "Flash Restoring", but the [RESET] and [BUSY] has been blinking in red, that indicates a PCB problem should be excluded.

• RS-485 Connection: HOST RX & HOST TX LED

[HOST RX] : When receiving incoming data from the host PC, the green LED will keep blinking

[HOST TX] : When transmitting the data back to the host PC, the red LED will be blinking

